

Technical sheet :

# **BIG BAG HANDLER**

---



## **Benefits**

- Increases efficiency & safety of big bag handling.
- Main structure made of tubes- limits the risk of bag damages & fall.
- Elevated structure- prevents any damage of trailer's roof while loading.
- Handles indifferently big bags with 1, 2 or 4 ears.

## **Technical characteristics**





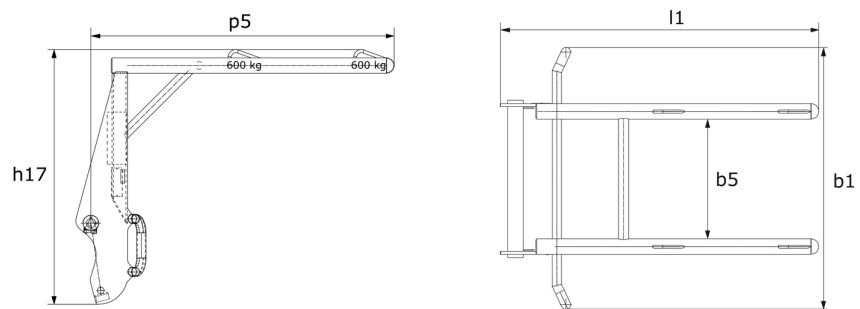

- Total capacity of 2400 kg.
- 4 loading points with 600 kg capacity each.
- 4 bag stoppers mounted on each loading point- limit the risk of bag falling.
- Anti-swing bag stabilizer, increases stability.

# Big Bag Handler - Dimensional drawing



Technical characteristics		HBB 1500 / 2400	HBB 2100 / 4000
Distance to center of gravity (mm)		388	459
Capacities			
Capacity (kg)		2400	4000
Weight and dimensions			
Fork spread (mm)	b5	-	700
Overall height (mm)	h17	1322	1322
Width (mm)		1356	1356
Length (mm)		1643	2181
Depth (mm)	p5	1300	2103
Overall weight (kg)		186	285
Working Parameters			
Machine Equipement		✗	✗
Hydraulic system		No	No
Fork spread minimum (mm)	b5	700	-
Fork spread maximum (mm)	b5	700	-
Other Data for Attachments			
Carriage type		Manitou	Manitou
Machines compatibility		HBB 1500 / 2400	HBB 2100 / 4000
Reference number		931627	52691660
Skid Steer Carriage reference		52578030	-
4 point Carriage		52742058	-
Euro Carriage		52742059	-
GCT 3-14		X	-
GCT 3-14 +		X	-
MLA-T 533-145 V+ - ST5		X	-
MLT 420-60 H		X	-
MLT 625-75 H		X	-
MLT 630-105 ST4		X	-
MLT 630-105 V CP ST4		X	-
MLT 630-105 V ST4		X	-
MLT 630-115		X	-
MLT 630-115 V		X	-
MLT 630-115 V CP		X	-
MLT 635-130 PS+		X	-
MLT 635-140 V+		X	-
MLT 730-115 V		X	-
MLT 730-115 V CP		X	-
MLT 730-115 V CP ST4		X	-
MLT 733-115		X	-
MLT 733-115 LSU		X	-
MLT 733-115 ST4		X	-
MLT 737-130 PS+		X	-
MLT 737-130 PS+ ST4		X	-
MLT 741-130 PS+		X	-
MLT 840-145 PS+		X	-
MLT 841-145 PS+		X	-
MLT 845-100 H		X	-
MLT 845-120		X	-
MLT 940-140 V+		X	-
MLT 961-145 V+ L		X	X
MLT 961-160 V+ L		X	X
MLT 1040-145 PS+ L		X	-
MLT 1041-145 PS+L		X	-
MLFX 625-75 H		X	-
MLFX 732		X	-
MLFX 735 T LSU		X	-
MLFX 840-140 PS+		X	-
MLFX 841 - 145 PS+		X	-
MLFX 845-120		X	-
MLFX 845-120 H		X	-
MLFX 961-145 V+ L		X	X
MLFX 961-160 V+ L		X	X
MLFX 1040-140 PS+ L		X	-
MLFX 1041-145 PS+L		X	-
MRT 1640 Easy 3B S2 360°		X	-
MRT 1640 Easy 3B S2 400°		X	-
MRT 1640 Easy T4 S2 360°		X	-
MRT 1840 Easy T4 S2 360°		X	-
MRT 1840 Easy T4 S2 400°		X	-
MRT 2145 Easy 3B S2 360°		X	-
MRT 2145 Easy 3B S2 400°		X	-
MRT 2145 Easy T4 S2 360°		X	-
MRT 2145 Easy T4 S2 400°		X	-
MRT 2470 Privilège Plus		X	-

Machines compatibility	HBB 1500 / 2400	HBB 2100 / 4000
MRT 2545 Easy 3B S2 360°	X	-
MRT 2545 Easy 3B S2 400°	X	-
MRT 2545 Easy T4 S2 360°	X	-
MRT 2545 Easy T4 S2 400°	X	-
MRT 3050 Privilege Plus	X	-
MRT 3255 Privilege Plus	X	-
MRT-X 1440 Easy 400°	X	-
MRT-X 1640 Easy 360°	X	-
MRT-X 1640 Easy 400°	X	-
MRT-X 1840 Easy 360°	X	-
MRT-X 1840 Easy 400°	X	-
MRT-X 2470 Privilege Plus	X	-
MRT-X 2545 Easy 360°	X	-
MRT-X 2545 Easy 400°	X	-
MRT-X 3050 Privilege Plus	X	-
MRT-X 3255 Privilege Plus	X	-
MT 420 H	X	-
MT 625 HA	X	-
MT 733 Easy	X	-
MT 933 Easy	X	-
MT 1033 easy	X	-
MT 1135	X	-
MT 1135 H easy ST5	X	-
MT 1335	X	-
MT 1440	X	-
MT 1440 A	X	-
MT 1440 HA	X	-
MT 1840	X	-
MT 1840 A	X	-
MT 1840 HA	X	-
MT-X 625 H	X	-
MT-X 733	X	-
MT-X 1033	X	-
MT-X 1440	X	-
MT-X 1440 A	X	-
MT-X 1840	X	-
MT-X 1840 A	X	-
MXT 840 K	X	-
MXT 840 P	X	-
MXT 1740 K	X	-
MXT 1740 P	X	-
ULM 412 H	X	-
ULM 415 H	X	-

TABLE SYMBOL					
	No predisposition required		Hydraulic line		Return piping to hydraulic oil tank
	Electric predisposition		Platform predisposition		Tyre handler, cylinder handler predisposition



Siège Social

430 rue de l'Aubinière - 44150 Ancenis Cedex - France

Tel: +33(0)2 40 09 10 11 - Fax: +33 (0)2 40 09 10 97

[www.manitou.com](http://www.manitou.com)



This brochure describes versions and configuration options for Manitou products which may be fitted with different equipment. The equipment described in this brochure may be standard, optional or not available depending on version. Manitou reserves the right to change the specifications shown and described at any time and without prior warning. The manufacturer is not liable for the specifications given. For more information, contact your Manitou dealer. Non-contractual document. Product descriptions may differ from actual products. List of specifications is not comprehensive. The logos and visual identity of the company are the property of Manitou and may not be used without authorisation. All rights reserved. The photos and diagrams contained in this brochure are provided for information only.

MANITOU BF SA - Limited company with board of directors - Share capital: 39,668,399 euros - 857 802 508 RCS Nantes